

TRIPOLIET



INSTRUCTION MANUAL

MODEL 3432-A

SIGNAL GENERATOR

MANUAL ONLY \$.75

MODEL 3432-A

SIGNAL GENERATOR

TABLE OF CONTENTS

SECTION I. DESCRIPTION

	Page
Technical Data	3
General	4
Circuit	4

SECTION II. OPERATION

	Page
General	5
Alignment of Receivers	6
T R F Receivers	6
Super-Heterodyne Receivers	7
I. F. Alignment	7
R. F. and Antenna Alignment	7
Oscillator Alignment	8
Oscillator Padding	8
F. M. Receivers	8
TV-I F Alignment	9

SECTION III. MAINTENANCE & PARTS

	Page
General	10
Calibration	10
Parts Location	12
Replaceable Parts	13
Wiring Diagram	14
Warranty	15

TRIPLET

MODEL 3432-A

**SIGNAL
GENERATOR**



RANGE SELECTOR

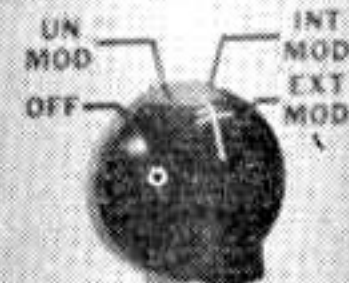
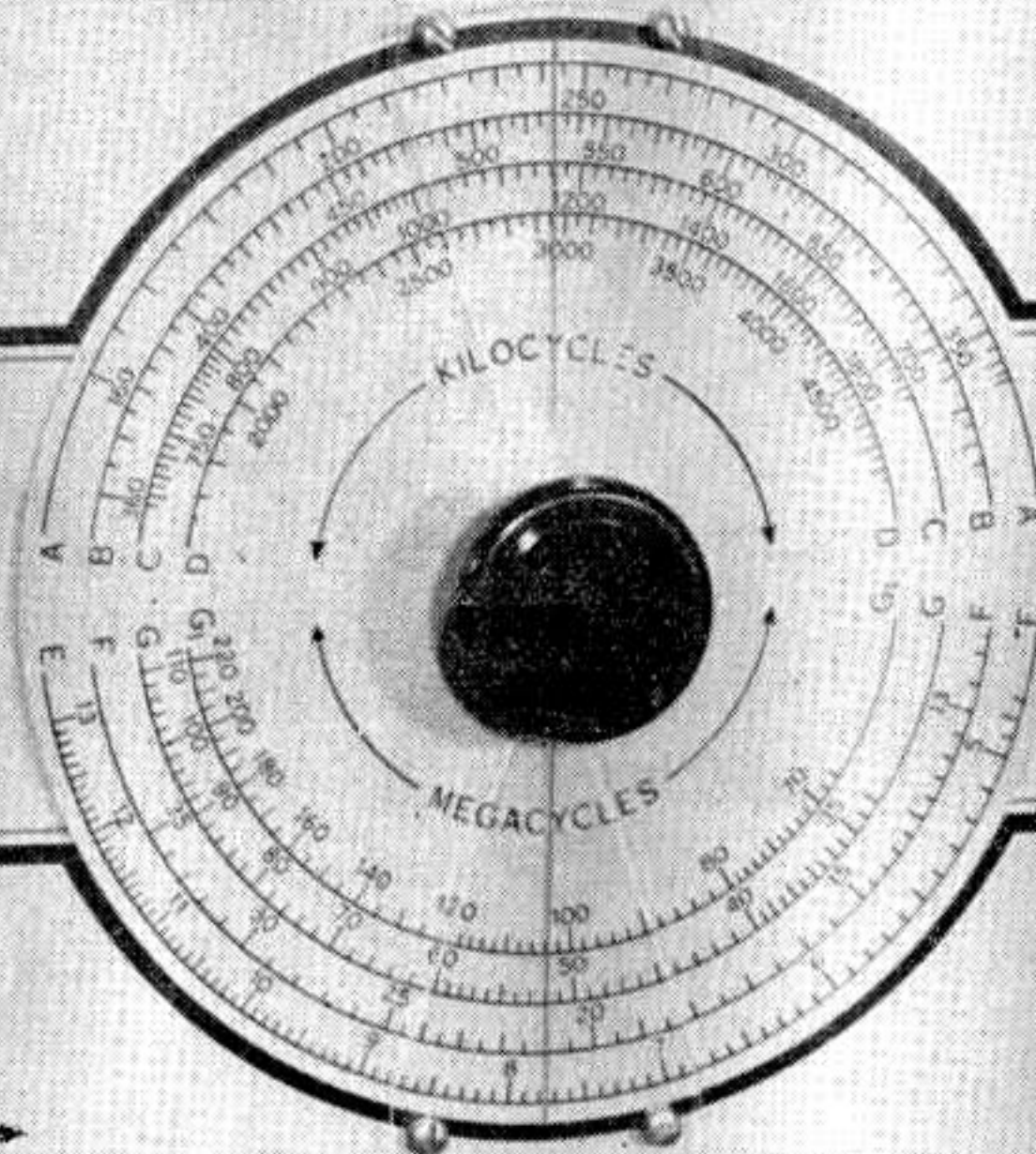

CIRCUIT SELECTOR



R. F. SELECTOR

R. F. OUTPUT



ATTENUATOR



AUDIO

EXT. MOD.
A. F. OUTPUT



Model 3432-A

Section 1

DESCRIPTION

TECHNICAL DATA

FREQUENCY —	Band	Kilocycles	Band	Megacycles
	A	160-370	E	4.85-13
	B	360-735	F	12.5 -35
	C	715-1875	G	34-110
	D	1825-4950	G (Harmonic)	68-220

RANGE SELECTOR — 7 — position follow-up coil switching. All coils are shorted except the one in use.

R. F. SELECTOR — 3 — position step attenuator.

OUTPUT ATTENUATOR — Provides fine control of R. F. output to coaxial cable connector.

CIRCUIT SELECTOR — Provides for internally modulated signal (Variable 0 to 100% at 400 cycles), variable amplitude of external modulation 40 to 15,000 cycles, unmodulated signal, & variable audio 0-4 volts at 400 cycles.

GENERAL DESCRIPTION

CASE — Metal with black baked enamel suede finish. Overall dimensions 15 11/32" x 11 1/32" x 6 1/4". Black leather strap handle, rubber feet.

KNOBS — Black bar (rectangular with skirt) streamlined design.

PANEL — Silver, black, and red etched aluminum.

OUTPUT LEAD — Co-axial cable approximately 3 feet long.

OUTPUT CONNECTIONS — Low capacity coaxial cable fitting for R. F. output. Two jacks for A. F. output and external modulation.

DIAL — Large 6 3/4" diameter etched aluminum.

POWER SUPPLY — 115 Volt, 50-60 cycles AC.

1. GENERAL

The Triplett Model 3432-A Signal Generator consists of an R. F. Oscillator calibrated in seven fundamental bands covering a frequency of 160 KC to 110 MC with overlap on each band. One harmonic band range G_1 is also provided for use at higher frequencies.

The cathode follower is coupled to the attenuator control and to the Low-Med-Hi switch. The R. F. voltage is available at the front panel through a low capacity coaxial cable.

The unit is provided with a 400 cycle A. F. Oscillator with variable control which provides 0-100 percent modulation of the R. F. Signal and approximately 4 RMS Volts A. F. signal to the A. F. jacks for external use. The black jack is ground.

Provision for external modulation of the R. F. signal is also provided.

Power for the unit is obtained from the 115 Volt 50-60 cycle power supply.

2. CIRCUIT

R. F. OSCILLATOR AND ATTENUATOR—This oscillator uses $\frac{1}{2}$ of a 12AU7 tube in a colpitts circuit with the R. F. coils connected to a follow-up shorting type Range Selector switch which permits the selection of each range as indicated by the Range Selector on the front panel.

The second $\frac{1}{2}$ of the 12AU7 is capacity coupled to the R. F. section and is used as a cathode follower to the output attenuator.

A. F. OSCILLATOR—The A. F. Oscillator uses a 6C4 tube in a transformer—coupled 400 cycle audio circuit with a separate winding for coupling the A. F. voltage to the grid of the 12AU7 R. F. oscillator tube. The percentage of modulation is adjusted with the audio control and is variable between zero and 100 per cent. A. F. signal of approximately 0-4 RMS Volts is also available at the “A. F. OUTPUT” jacks. Black jack is ground; red jack is Hi A. F. located on the front panel. A circuit selector switch is provided for controlling the modulation and A. F. signal output voltage. This switch also provides for external modulation of the R. F. signal with the percentage of modulation being controlled by the audio control.

POWER SUPPLY—The power supply uses a 6X4 full wave rectifier tube with its D. C. output filtered by 1000 ohms and a dual 30 mfd. capacitor.

Section II OPERATION

1. GENERAL

Before using the 3432-A Signal Generator, read the operating instructions carefully. The Model 3432-A Signal Generator is designed to operate on 115 volt, 50-60 cycle alternating current. The circuit selector switch controls the line voltage to the power supply. For accuracy, the unit should be allowed to warm up at least 15 minutes before making any alignments.

The controls and output connectors are clearly identified by the markings on the panel and serve the following purposes:

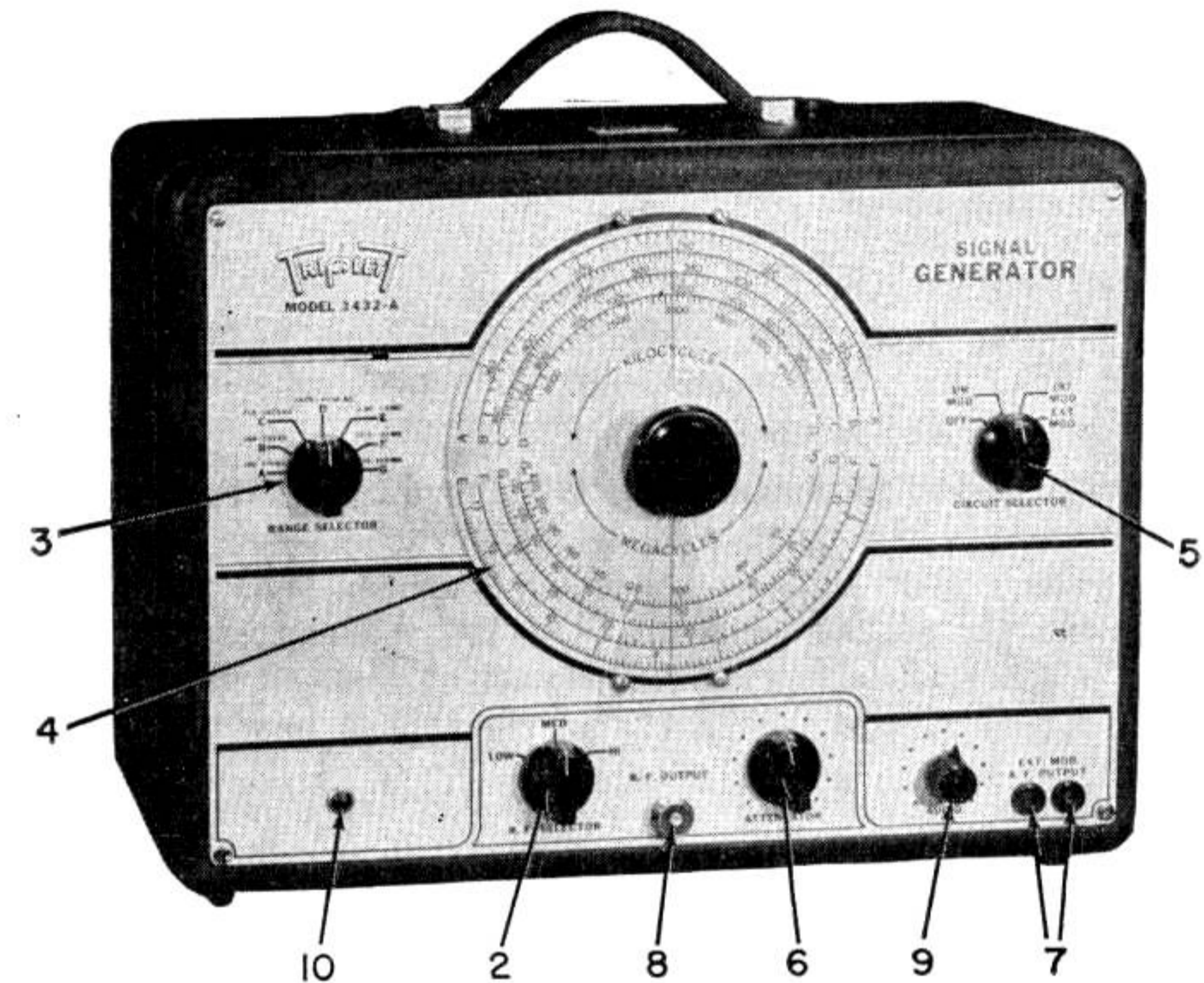

- 1 — “OFF-ON” — Power Switch on circuit selector switch (5).
- 2 — “RF SELECTOR” — Switch for selection of “Low-Med-Hi” output.
- 3 — “RANGE SELECTOR” — R. F. Oscillator range selector switch.
- 4 — “MAIN DIAL” — Calibrated R. F. Signal in seven ranges controlled by the vernier tuning knob.
- 5 — “CIRCUIT SELECTOR” — Modulation and audio output selector.
- 6 — “ATTENUATOR” — Adjustment of R. F. signal from cathode follower.
- 7 — “EXT. MOD.” and “A. F. OUTPUT” — Jacks for audio output and external modulation signal. Black jack is ground, Red jack is Hi A. F.
- 8 — “R. F. OUTPUT” — Connection to coaxial cable for R. F. output signals.
- 9 — “AUDIO” — Control for audio output, internal and external modulation.
- 10 — “PILOT LIGHT” — Indicating line voltage on.

2. ALIGNMENT OF RECEIVERS

Modern radio receivers employ from two up to eight or more circuits to achieve the selectivity desired.

These circuits, however, are of little benefit unless all of them are working at their proper frequencies simultaneously. Only someone who has adjusted a receiver on which all of the adjusting screws have been tightened can realize how dead a receiver can be when all of its tuned circuits are considerably out of adjustment. The purpose of aligning a radio receiver is two-fold: to adjust it for maximum performance, and to make the dial indicate to within two or three percent the frequency of the station being received. Since a trimmer adjustment is more sensitive when the circuit capacity is low, the trimmer adjustment is usually made near the high frequency end of the tuning range. If the adjustment is made at the very end of the range, the maximum mistracking over the adjacent portion of the band will be greater than if an alignment point is chosen some small distance from the extreme high-frequency end of the tuning range. In the broadcast band, 1400 KC is the usual choice and is the frequency recommended as standard by the Institute of Radio Engineers. On short-wave bands on the same receiver, it is a good practice to align them at the same position on the gang condenser. Most manufacturers give the correct alignment information in the receiver instruction book.

TRF RECEIVERS—On a TRF receiver, all tuned circuits operate simultaneously at one frequency. Aligning a factory built receiver having dials calibrated to match the coils and condensers, the dials are set to frequency one wishes to receive.

To align a TRF receiver connect the RF Output cable to the antenna and ground of the receiver. Connect a model 630 or some type of output meter to the speaker voice coil to indicate maximum output. With the receiver dials set to 1400 KC set the signal generator to 1400 KC using Band "C" on the Range Selector switch (3). The Circuit Selector switch (5) must be set on INT. MOD. Set Attenuators (2) and (6) to the lowest usable signal that will read on the output. Adjust tuning condensers for maximum output.

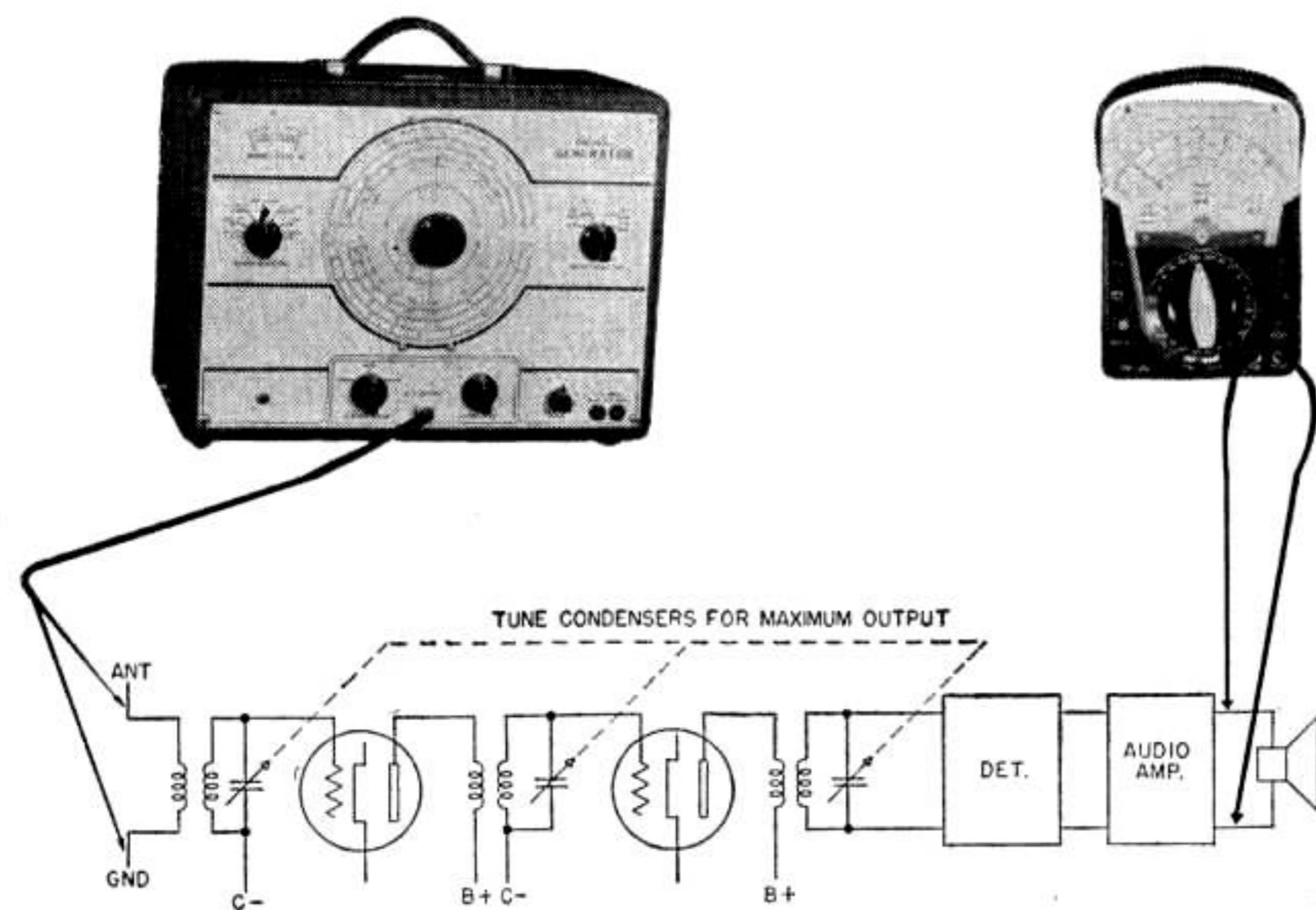

TRF Alignment

SUPER-HETERODYNE RECEIVERS—On a Super Heterodyne receiver, circuits must operate at three different frequencies, properly related, if satisfactory performance is to be obtained. Beginning with the circuit closest to the output tubes, the intermediate-frequency circuits must all operate at the same frequency in order to give satisfactory amplification. Actually they will work over a wide frequency range, but if they are operated very far from the intermediate-frequency specified for the given dial, coils and tuning condensers, the dial indication will be in error more than the customary few percent and, in the case of receivers employing special cut tracking plates in the oscillator condensers, serious mistracking of the oscillator with other tuned circuits will result producing a loss in sensitivity and reduction in image-ratio.

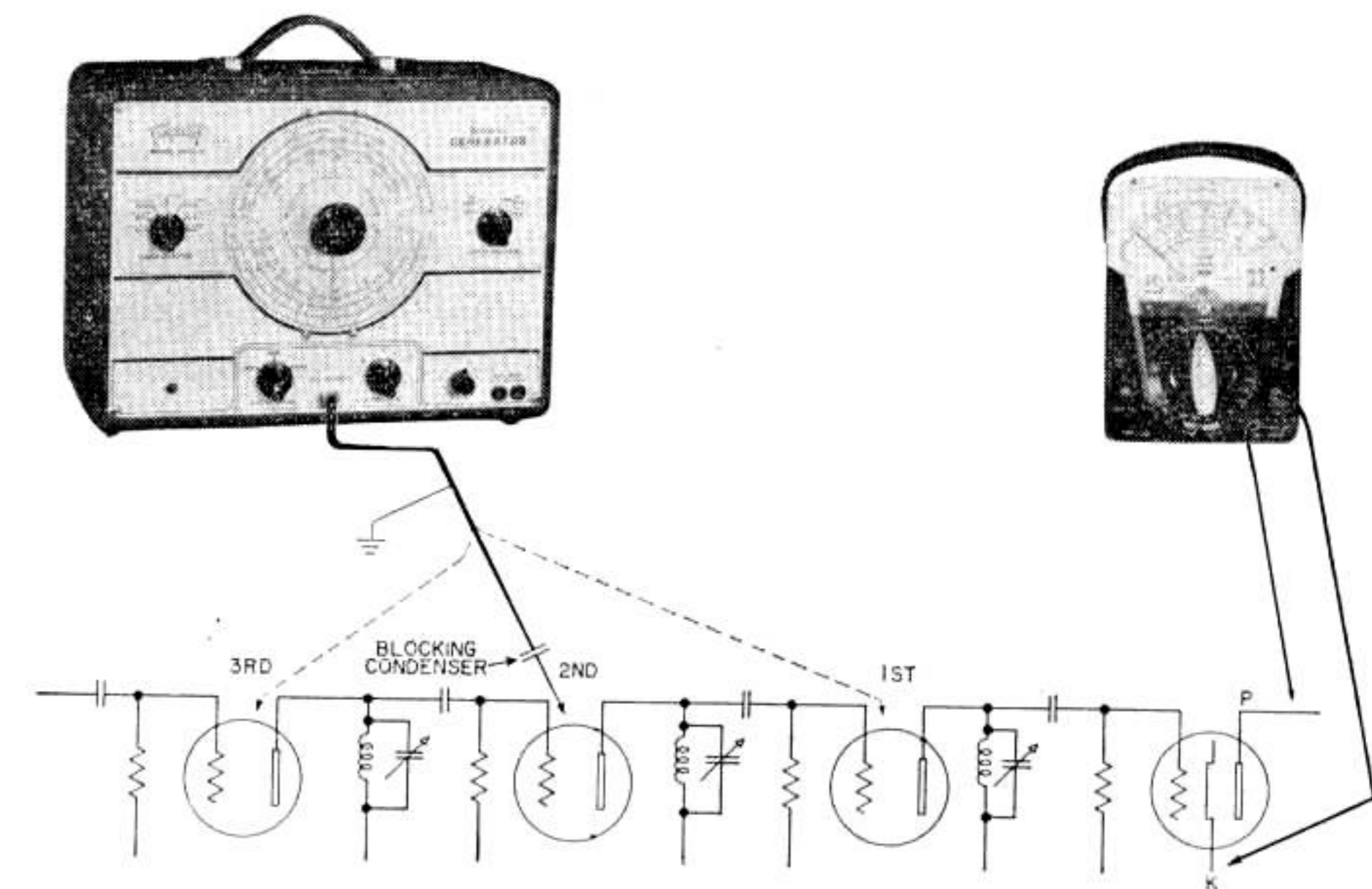

I. F. ALIGNMENT—The first adjustment on a Super-Heterodyne receiver is to align the intermediate-frequency amplifier at the correct frequency. The transformer should be adjusted to give the strongest signal by adjusting, in turn, each of the adjustments on all of the I. F. transformers. The intermediate-frequency stages should be aligned first and in their reversed order starting at the stage immediately preceding the second detector. For this procedure, the coaxial cable is connected to the grid of the tube preceding the stage under alignment and the ground clip to the receiver ground with the Signal Generator set to the I. F. frequency specified by the manufacturer. Since it is essential that the operating characteristics of a stage be un-altered, this connection to the grid should be made with the grid lead in place. This procedure should be continued until all of the I. F. transformers have been aligned properly.

R. F. AND ANTENNA ALIGNMENT—To align the R. F. amplifier circuit. On the band below 6 megacycles, the frequency of the R. F. amplifier circuit has very little effect upon the oscillator frequency, but at higher frequencies the adjustments of the R. F. circuit have a slight effect upon the frequency of the oscillator; consequently, it is necessary when aligning a high frequency R. F. amplifier to ROCK the gang condenser very slightly as the alignment proceeds to be sure that a shift in oscillator frequency has not shifted the Heterodyne signal out of range of the I. F. amplifier. The antenna circuit is then aligned by adjusting the antenna coil trimmer.

OSCILLATOR ALIGNMENT—Connect the appropriate dummy antenna between the high side of the Signal Generator output and the antenna connection of the receiver and set the frequency of the Signal Generator to an appropriate frequency on the band to be aligned; this is usually about 80% of the maximum frequency tunable on that band—set the receiver dial to the corresponding frequency. Turn the volume and sensitivity controls of the receiver full on; then turn the generator attenuator to high output and adjust the oscillator trimmer until a signal is heard. Reduce the signal from the Signal Generator as alignment proceeds, always using as little input as possible because weak signals permit a more accurate alignment than strong signals. Care should be taken that the alignment condenser and not the series padding condenser be used for this adjustment.

OSCILLATOR PADDING—Shifting the tuning dial to a point about 10% up from its lowest frequency, the oscillator circuit should be padded for best tracking with the antenna and R. F. circuits by adjusting the series padding capacitors as recommended by the receiver manufacturer. If the radio set is sufficiently sensitive to produce a readily discernible hiss in the speaker, the easiest way to pad the oscillator circuit is to adjust the padding condenser for maximum hiss or minimum noise. When this point is padded, it is well to turn to the high frequency end and re-align that part of the band.

F. M. RECEIVERS—For high speed visual alignment of F. M. receivers, a frequency modulated test oscillator giving a strong frequency modulated signal over a range of several hundred kilocycles and a Cathode Ray Oscillograph are desirable.

However, it is possible to make all necessary alignment operations with this equipment by the use of the 3432-A Signal Generator and a sensitive voltmeter such as Triplett Model 630, 630-NA or 630-A. The following procedure will be helpful in using the fixed frequency method of alignment of F. M. receivers, but the receiver manufacturer's instructions should be followed wherever possible.

Connect the 3432-A coaxial output cable to the grid of the limiter tube and ground. Connect a sensitive voltmeter (20,000 ohms per volt or better) across the two cathodes of the discriminator tube. Set the Signal Generator to the exact I. F. frequency as specified by the receiver manufacturer and, using an unmodulated signal, adjust the primary trimmer of the discriminator transformer for maximum meter reading. Now adjust the secondary trimmer until a zero voltage reading is obtained. Care must be used in selecting the correct I. F. frequency on the Signal Generator and this setting must not be changed until all the I. F. transformers are adjusted. Without changing the Signal Generator frequency setting, shift the coaxial cable to the R. F. input grid of the first detector or mixer. I. F. trimmer alignment is started with the trimmer at the input of the limiter stage and proceeds by adjusting each trimmer, in turn, back through the trimmer across the output of the first detector. Repeat the trimmer adjustment in the same order using great care to obtain exact peak adjustment as indicated on the voltmeter; this will insure that the output of the discriminator will be equal on both sides of the frequency modulated carrier. The alignment of the R. F. mixer and oscillator in an F. M. receiver is exactly the same as that used in the A. M. receiver as described earlier in this book.

If the above procedure is used and the receiver manufacturer's instructions are followed carefully, correct alignment of F. M. receivers may be accomplished with the 3432-A A. M. Signal Generator.

TV-IF ALIGNMENT—The model 3432-A is an ideal AM Generator for TV-IF alignment as the "F & 6" Band covers 18MC to 40MC. The alignment of IF stages in TV sets differs from IF in super-heterodyne receivers. In super-heterodyne receivers the IF stages are all tuned to the same frequency. In TV-IF stages they are usually stagger tuned, meaning each stage is tuned at a different frequency as shown in illustration below.

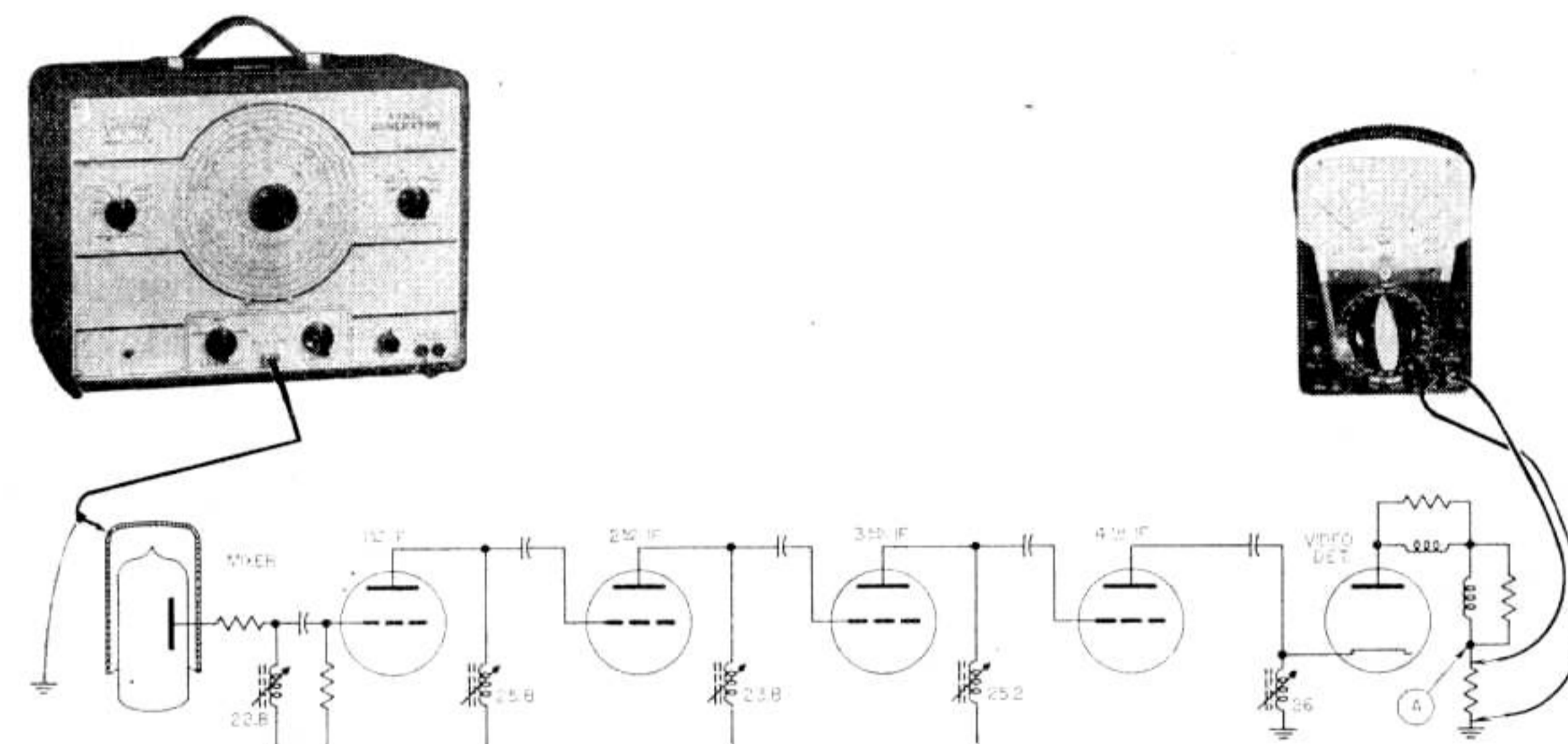

The model 3432-A can also be used as a marker generator with model 3435 sweep generator for all TV alignment and service work. When using a sweep generator it is necessary to use an oscilloscope to view the wave form.

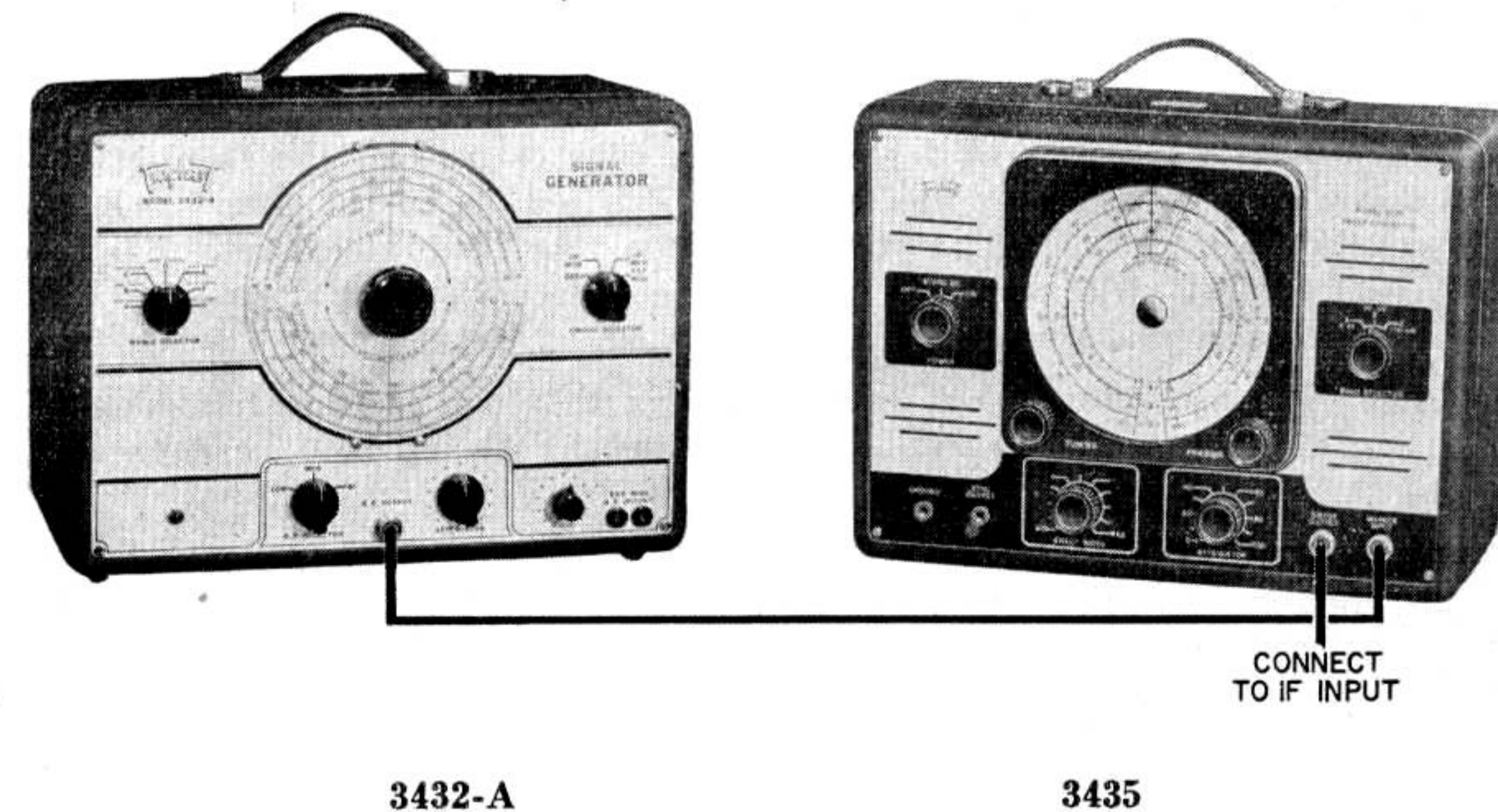

3432-A

3435

Section III

MAINTENANCE AND PARTS LIST

1. GENERAL

The Model 3432-A Signal Generator is designed to require little or no maintenance. With the exception of replacing tubes when they are defective, and rechecking calibration whenever R. F. oscillator tube 12AU7 is changed, no trouble should be experienced with this unit. Illustrations are provided to acquaint the user with the various circuits and calibration.

2. CALIBRATION

If the R.F. Oscillator tube should require replacement, it may be necessary to recalibrate the R.F. Oscillator circuits to the correct frequency printed on the calibrated dial. It will be necessary to have a crystal oscillator or other source of accurate signals that will produce a fundamental or harmonic signal when connected to a receiver that will tune the following frequencies or their harmonics.

CALIBRATION FREQUENCIES

Oscillator Band	Coil Adjustment	Trimmer Adjustment
A	160 KC - L1	350 KC - C5
B	360 KC - L2	700 KC - C6
C	750 KC - L3	1800 KC - C7
D	2000 KC - L4	4500 KC - C8
E	5 MC - L5	13 MC - C9
F	13 MC - L6	35 MC - C10
G	35 MC - L7	110 MC - C11

Remove the four screws located at the four corners of the front panel. The entire Signal Generator unit can then be lifted out of the case. Remove the coil box back cover. The "G" band should be calibrated first. Set the "RANGE SELECTOR" to band "G" and connect the coaxial cable to the receiver antenna and ground terminals.

A crystal oscillator or other signal source that will provide fundamental or harmonic signals at the calibration frequencies should also be connected to the same receiver terminals.

Allow the Signal Generator and receiver to warm up at least thirty minutes before any adjustments are made. Tune the receiver to the frequency listed for coil adjustment of "G" band (35MC). A signal from the crystal oscillator should be heard.

Tune the Signal Generator dial until a signal is heard beating with the crystal signal in the receiver when the Signal Generator dial is near the

calibration frequency (35 MC). Make wire adjustments on (L7) shown on Wiring Diagram Page 14 until the dial reading is correct.

Now tune the receiver to the frequency listed for band "G" (110MC). The signal from the crystal oscillator again should be heard. Again tune the Signal Generator dial until its signal is heard beating with the crystal signal and carefully bend wires L7. until the dial reading is correct.

This procedure should be repeated several times until both calibration points on the Signal Generator dial are correct.

Care should be used in adjusting the receiver in order that the fundamental and not the image signal is used. The image signal is usually lower in frequency than the fundamental signal.

Recalibrate the other ranges following the same procedure using the correct calibration frequencies as given in the chart.

PARTS LOCATION

REPLACEABLE PARTS

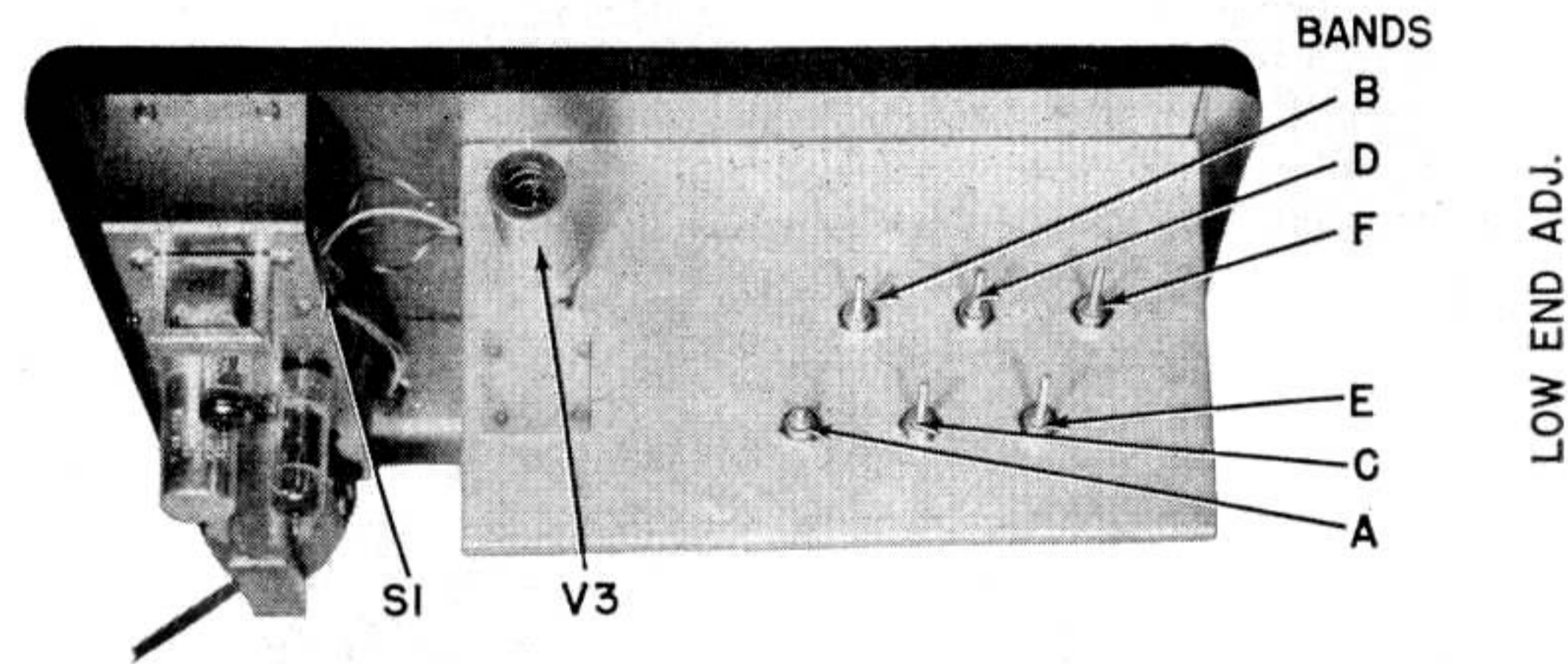

LOW END ADJ.

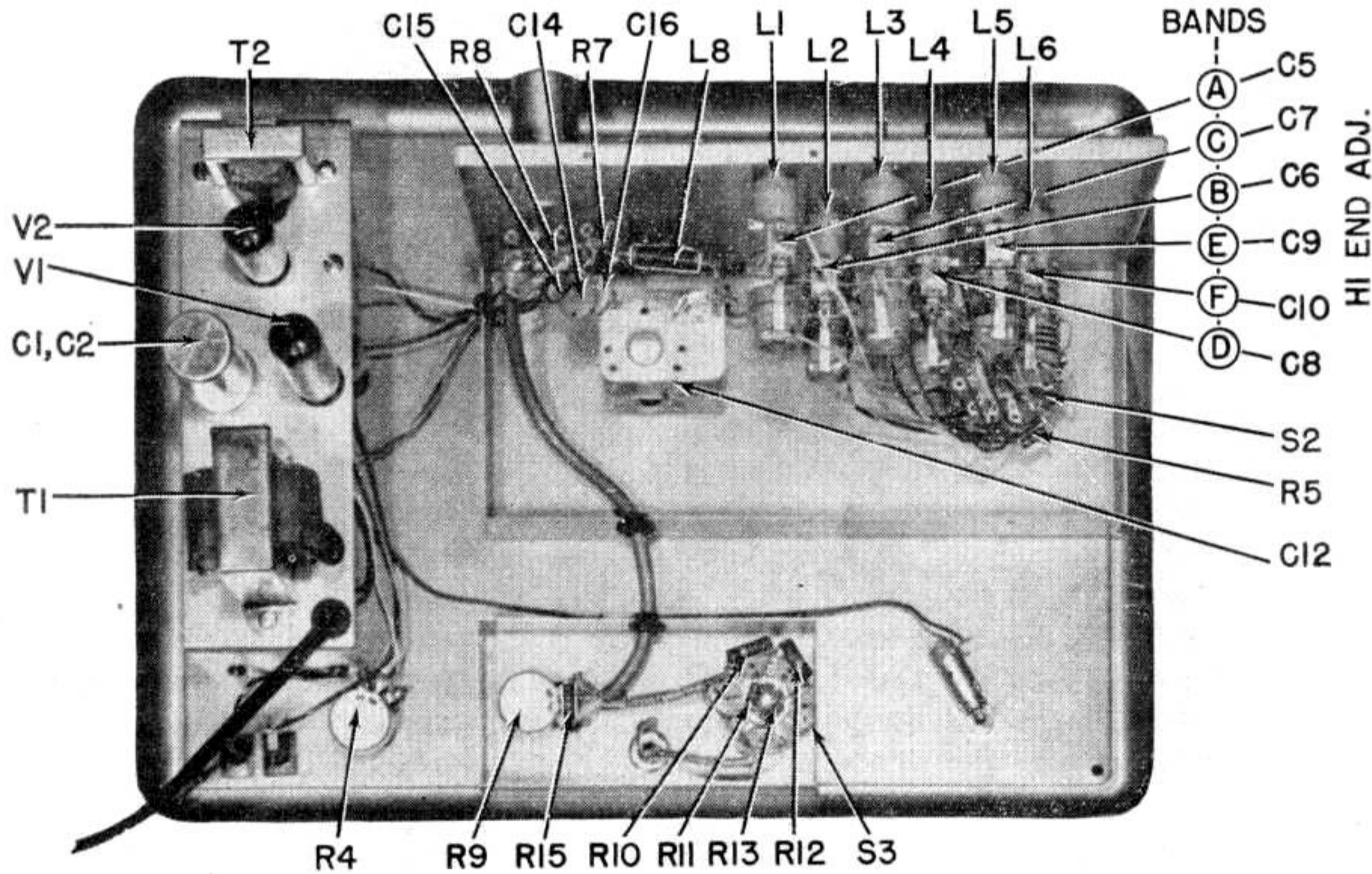

HI END ADJ.

Ref. No.	Quan.	Part Name	Description	Triplet Part No.
R1	1	Resistor	1K $\pm 10\%$, 1W, IRC	T-2601-1-1K
R2	1	Resistor	1K $\pm 10\%$, $\frac{1}{2}$ W, IRC	T-2601- $\frac{1}{2}$ -1000
R3, R8	2	Resistor	100K $\pm 10\%$, $\frac{1}{2}$ W, IRC	T-2601- $\frac{1}{2}$ -100K
R4	1	Resistor	5K $\pm 20\%$, IRC "Q" Control	T-16-116
R5	1	Resistor	10K $\pm 10\%$, $\frac{1}{2}$ W IRC	T-2601- $\frac{1}{2}$ -10K
R6	1	Resistor	20K $\pm 10\%$, $\frac{1}{2}$ W IRC	T-2601- $\frac{1}{2}$ -20K
R7	1	Resistor	68K $\pm 10\%$, $\frac{1}{2}$ W IRC	T-15-1657
R9	1	Resistor	2K $\pm 20\%$, IRC "Q" Control	T-16-115
R10, R12	2	Resistor	220 ohm, $\pm 10\%$, $\frac{1}{2}$ W IRC	T-2601- $\frac{1}{2}$ -220
R11, R13	2	Resistor	56 ohm, $\pm 10\%$, $\frac{1}{2}$ W IRC	T-2601- $\frac{1}{2}$ -56
R14	1	Resistor	2K $\pm 10\%$, $\frac{1}{2}$ W IRC	T-2601- $\frac{1}{2}$ -2000
R15	1	Resistor	200 ohm, $\pm 10\%$, $\frac{1}{2}$ W IRC	T-15-1535
C1, C2	1	Condenser	Can type, 30-30 mfd., 150v	T-43-178
C3	1	Capacitor	.1 mfd., 200v	43-135
C4	1	Capacitor	.047 mfd., 200v	43-132
C6	1	Capacitor	Trimmer, Arco 404, 6-60 mmfd	T-43-206
C5, C7, C8, C9				
C10	5	Capacitor	Trimmer, Arco 403, 3-35 mmfd	T-43-205
C12	1	Condenser	Variable,	T-43-194
C13	1	Capacitor	39 mmfd, disk, 600v	T-43-196
C14, C16	2	Capacitor	Disk, .001 mfd, 500 VDC, RMC	T-43-168
C15	1	Capacitor	18 mmfd, disk, 600v	T-43-197
C17	1	Capacitor	.25 Mfd, 200v, Paper	T-2631-P5
C18	1	Capacitor	.01 Mfd, disk, 600v, RMC	T-43-198
T1	1	Transformer	Power, Stancor, 3432-A	T-23-86
T2	1	Transformer	Audio	T-23-17A
S1	1	Switch	Selector, 12 pos., (4 active) 1 deck	T-22-280
S2	1	Switch	12 pos., (7 active) 3 deck, Oak	T-22-285
S3	1	Switch	12 pos., Wafer, (3 active) 1 deck, Oak	T-22-281
V1	1	Tube	6X4	T-2600-6X4
V2	1	Tube	6C4	T-2600-6C4
V3	1	Tube	12AU7	T-2600-12AU7
L8	1	Choke	Choke Assem., 7-7.5 μ H	T-3022-23
L1	1	Coil	Oscillator, "A" Band	T-2542A-110
L2	1	Coil	Oscillator, "B" Band	T-2542A-111
L3	1	Coil	Oscillator, "D" Band	T-2542A-112
L4	1	Coil	Oscillator, "C" Band	T-2542A-113
L5	1	Coil	Oscillator, "E" Band	T-2542A-114
L6	1	Coil	Oscillator, "F" Band	T-2542A-115

WIRING DIAGRAM MODEL 3432-A

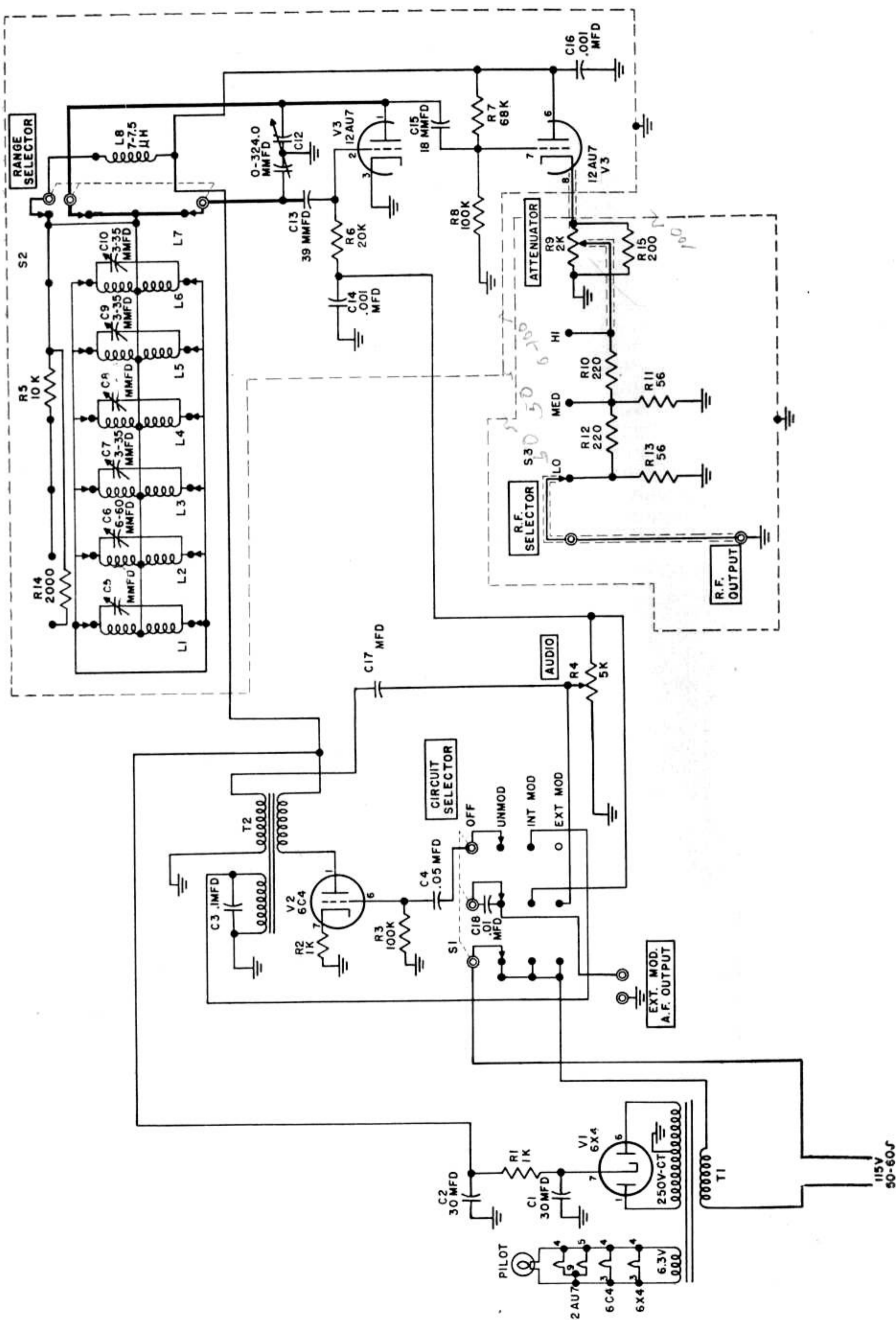

The Triplett Electrical Instrument Company warrants instruments manufactured by it to be free from defective material or factory workmanship and agrees to repair or replace such instruments which under normal use and service, disclose the defect to be the fault of our manufacturing. Our obligation under this warranty is limited to repairing or replacing any instrument or test equipment which proves to be defective, when returned to us transportation prepaid, within ninety (90) days from the date of original purchase.

This warranty does not apply to any of our products which have been repaired or altered by unauthorized persons or service stations in any way so as, in our judgment, to injure their stability or reliability or which have been subject to misuse, negligence, or accident, or which have had the serial number altered, effaced, or removed. Neither does this warranty apply to any of our products which have been connected, installed, or adjusted otherwise than in accordance with the instructions furnished by us. Accessories including all vacuum tubes and batteries not of our manufacture used with this product are not covered by this warranty.

The Triplett Electrical Instrument Company reserves the right to discontinue models at any time, or change specifications or design, without notice and without incurring any obligation.

Upon acceptance of the material covered by this invoice the purchaser agrees to assume all liability for any damages and bodily injury which may result from the use or misuse of the material by the purchaser, his employees, or others, and that The Triplett Electrical Instrument Company shall incur no liability for direct or consequential damage of any kind.

Parts will be made available for a maximum period of (5) years after the manufacture of this equipment has been discontinued. Parts include all materials, charts, instructions, diagrams, accessories, et cetera, which were furnished in the standard or special models.

This warranty and conditions of sale are in lieu of all others expressed or implied and no representative or person is authorized to assume for us any other liability in connection with the sale of our products.

The Triplett Electrical Instrument Co.
Bluffton, Ohio

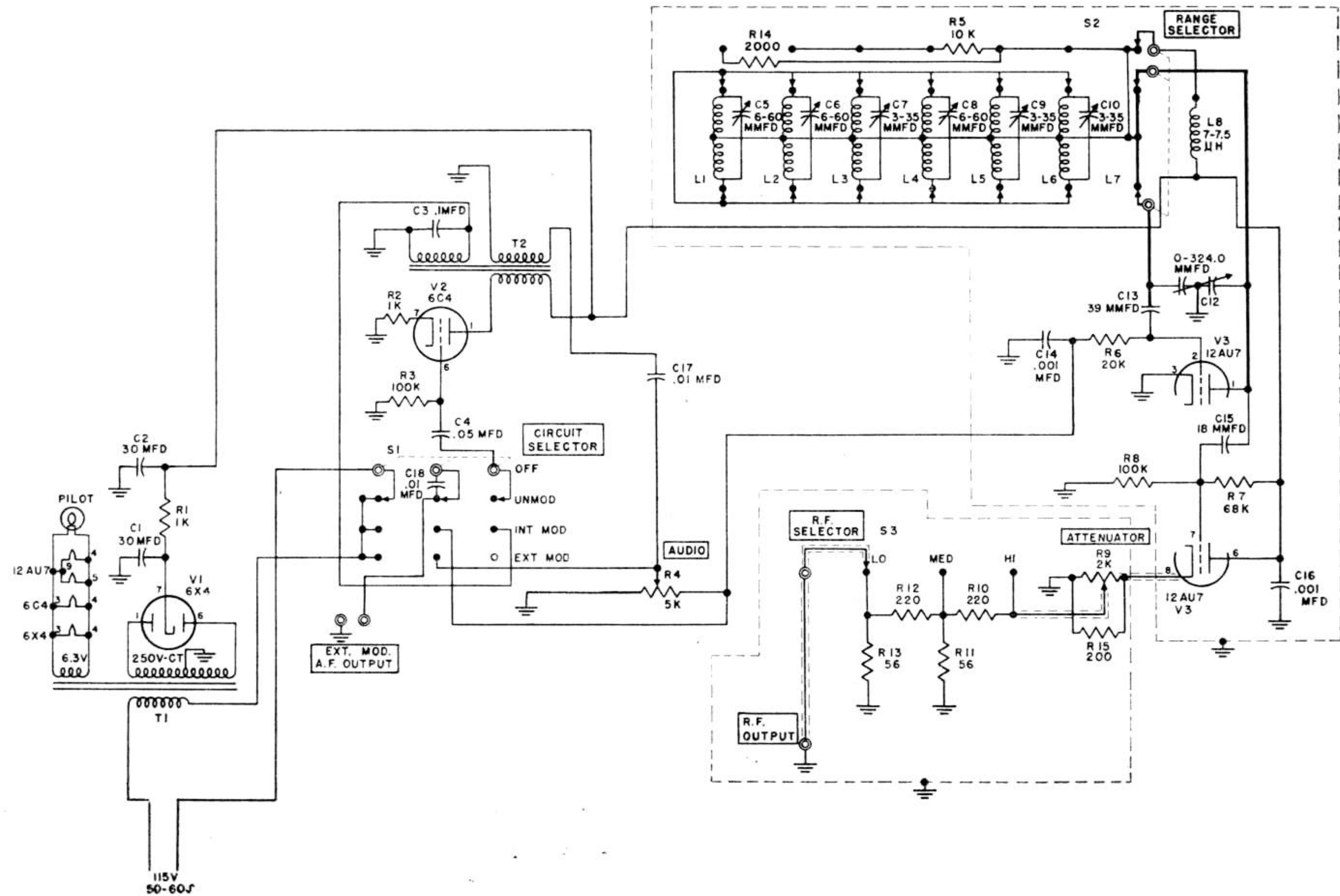

3432-A WIRING DIAGRAM

THE TRIPLET ELECTRICAL INSTRUMENT CO.

BLUFFTON, OHIO, U. S. A.